

Product Specification

Display

Panel Size	65"
Panel Type	TFT LCD Module with DLED Backlight. IPS
Display Area	H1428.48 mm x V803.52 mm
Aspect Ratio	16:9
Resolution	UHD 3840 x 2160 (pixels)
Colours	1.07B colours (10 bit)
Brightness	350 nits (typ.)
Contrast Ratio	1200:1 (typ.) / 5000:1 (DCR)
Response Time	8.0ms
Viewing Angles	H = 178, V=178 typ
Backlight Life	50,000 Hours (Min)
Surface Treatment	Hardness: 7H Anti-glare coating
Bezel	Slim
Orientation	Landscape

Platform

Processor	ARM Cortex-A73*4 + Cortex-A53*4
RAM	4 GB
Storage	32 GB

Touch

Type / Tech	Ultra Fine Touch Technology (IR Recognition)
Touch Resolution	32768 x 32768
Touch Point	Windows: 40 points of touch Android: 20 points of touch

ViewSonic 50 Series

Input

HDMI	x 3 HDMI 2.0 (3840 x 2160 @ 60Hz, HDCP2.2, HDMI1 with CEC/ARC)
RS232	x 1
OPS	x 1
WiFi	x 1 module slot

Output

HDMI	x 1 (4k @ 60Hz)
Audio	x 1 (Earphone out)
SPDIF	x 1 (Optical)

LAN

RJ45	x 2
-------------	-----

USB

Type A 2.0	x 2
Type A 3.0	x 4
Type B	x 2 for touch
Type C	x 1 (DP 1.2, USB 2.0, PD65W, Ethernet 100M)

Speakers

12W	x 2
16W Subwoofer	x 1

Product Specification

Ergonomics

Wall Mount 600 mm x 400 mm (VESA®)

Embedded OS Android 11

Bundle Software

Basic Annotation Software myViewBoard

Pro Annotation Software myViewBoard Whiteboard for Windows (Embedded in optional Windows Slot-in PC)

Wireless Presentation vCast/myViewBoard Display App

Special Features

All in one USB-port "SMARTPort™ USB to all channels

Simple LAN sharing Yes

between IFP and slot in device

Light Sensor Yes

Operating Conditions

Temperature 0°C to 40°C

Humidity 10% ~ 90% RH non-condensing

ViewSonic 50 Series

Power

Voltage 100 - 240VAC +/- 10% Wide Range

Consumption On: 95W (typ)

Off: ≤ 0.5W

Weight

Net 40.5 KG

Gross 49.7KG

Regulations

cTUVus, FCC/ICES003, Energy Star 8.0, EMC/CE, CB/LVD, GOST-R/EAC, UkrSEPRO, EPEAT, UKCA, EK-EEL, Mexico NOM, Mexico Energy, BSMI, BIS, LBL (Low Blue Light Certification), Flicker Free, Green BOM, RoHS, ErP-Eco, SCIP, REACH, TPCH, Packing waste, CA65, PAIA

Compatible Slot-in PC

VPC2-O Series / VPC2-O-B Series / VPC25-W33-O1-1B / VPC27 W53-O1-1B / VPC23-WPO-17 / VPC12-WPO-18

Dimensions

Physical L1488 mm x H897 mm x D90 mm

Packaging L1669 mm x H1010 mm x D223 mm

Product Specification

What's in the box?

- Power Cord
- Remote Control with AAA batteries
- Touch USB cable
- Touch Pen x 2
- Quick Start Guide
- Compliance Statement
- RS232 adapter
- Screw x 4
- HDMI cable
- Clamp x 5
- Camera Plate x 1

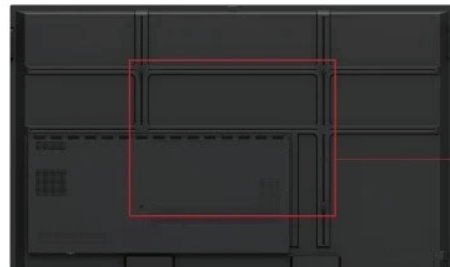
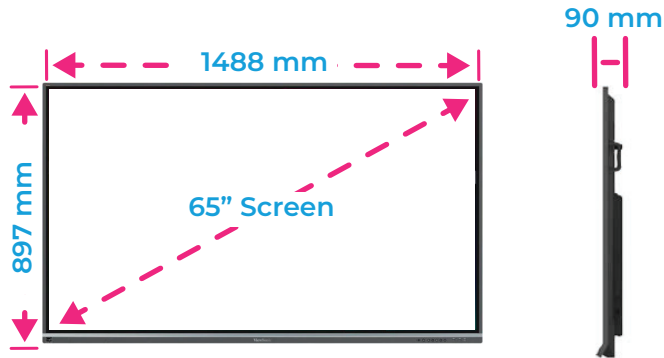

ViewSonic 50 Series

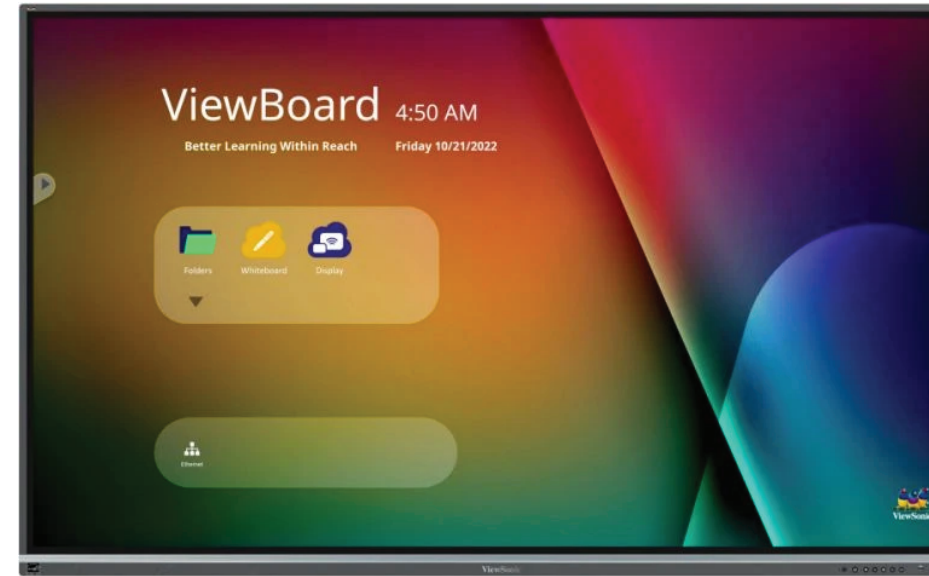

Upto 40 points of touch

USB Type-C

2 Speakers & 1 Subwoofer

350 nit brightness

Light Sensor

Dual Band Wi-Fi

Ultra Fine Touch Technology

3840 x 2160 pixels

HDMI

16:9 Aspect Ratio